

Emergency safety showers – Part 3: Body showers for production and logistic sites

Sicherheitsnotduschen — Teil 3: Körperduschen für Betriebe und Umschlaganlagen

Douches de sécurité — Partie 3: Douches pour le corps utilisées en fabrique et en dehors

Intended to replace
DIN 12899-3:1992-10

Content:	Page
Foreword.....	3
Introduction	3
1 Scope	3
3 Terms and definitions.....	4
4 Performance	5
4.1 Classification.....	5
4.2 Flow rate of water	5
4.2.1 Plumbed-in body showers	5
4.2.2 Tank showers	6
4.2.3 Combination showers	6
4.3 Water distribution	6
4.3.1 Type test	6
4.3.2 Body showers of classes I and II	6
4.3.3 Body showers of Class III and tank showers	7
4.4 Water quality.....	8
4.5 Water availability.....	8
4.6 Water temperature	8
5 Constructional installation requirements.....	8
5.1 Installation height	8
5.2 Free space	8
6 Valve.....	8
7 Shower head.....	9
8 Mechanical stability of tank showers	9
9 Manufacturer's information	9
10 Marking	9

Commencement of validity

This standard is effective from[release date].

Foreword

This standard includes safety-related specifications in the sense of the "German Act on Technical Equipment and Consumer products (GPSG)".

This document has been prepared by the Working Group "Laboratory fittings" of the DIN Technical Committee "Laboratory devices and furniture".

Modifications / Changes

Compared to the german standard DIN 12899-3:1992-10 the following modifications have been incorporated:

- a) the standard has been adapted to fit to the European standard series EN 15154;
- b) tank showers have been taken into the standard;
- c) terms and definitions have been specified;
- d) the type test method has been modified;
- e) requirements concerning the user's information have been added.

Introduction

Body showers for production and logistic sites are designed and intended to be installed in close range of persons working in a potentially hazardous area. The main purpose of these devices is to deliver immediately flushing fluid in sufficient volume to extinguish flames and/or to flush the body following exposure to injurious substances or heat. With this accomplished the injured person can proceed to medical care.

1 Scope

This document is a product specification, giving performance requirements for emergency safety body showers

- a) which are connected to a water supply or
- b) which are equipped with a store tank and optionally connected to an uninterrupted or a temporary water supply.

It is only applicable to safety body showers (in combination with safety eyewashes as well), which will be installed on industrial and logistic sites. DIN EN 15154-1 applies to safety body showers in laboratories. DIN EN 15154-2 applies to safety eyewashes on industrial sites and similar areas.

IMPORTANT — Depending on craft and place of installation attention shall be given to the avoidance of overheating through radiant heat or to the danger through refreezing.

This standard specifies requirements given in respect of the performance, installation, adjustment and marking of the showers as well as installation, operation and maintenance instructions to be given by the manufacturer.

2 Normative references

The following referenced documents are indispensable for the application of this document. For dated references, only the edition cited applies. For undated references, the latest edition of the referenced document (including any amendments) applies.

DIN 1055-4:2005-03, Actions on structures — Part 4: Wind loads

DIN 1055-5:2005-07, Actions on structures — Part 5: Snow loads and ice loads

DIN 1055-100:2001-03, Actions on structures — Part 100: Basis of design, safety concepts and design rules

DIN EN 420, Protective gloves — General requirements and test methods

DIN EN 15154-1, Emergency safety showers — Part 1: Plumbed-in body showers for laboratories

DIN EN 15154-2, Emergency safety showers — Part 2: Plumbed-in eyewash units

ISO 3864-1, Graphical symbols — Safety colours and safety signs — Part 1: Design principles for safety signs in work places and public areas

3 Terms and definitions

For the purposes of this document, the terms and definitions given in DIN EN 15154-1, DIN EN 15154-2 and the following apply.

3.1

emergency safety shower

device specially designed and intended to deliver a flushing fluid to extinguish flames and to sufficiently wash away contaminants or to dilute them, rendering them harmless

NOTE According to DIN EN 15154-1.

3.2

plumbed-in body shower

emergency safety shower that is permanently connected to a continuous water supply and designed to deliver water sufficient to flush the whole body

NOTE According to DIN EN 15154-1.

3.3

body shower with store tank tank shower

emergency safety shower that is self-sufficient and filled by a temporary water supply or which can be optionally connected to a continuous water supply

3.4

emergency safety eye wash unit

device specially designed and intended to deliver a flushing fluid to irrigate and flush the eyes and to sufficiently wash away contaminants or to dilute them, rendering them harmless

NOTE According to DIN EN 15154-2.

3.5**plumbed-in emergency safety eye wash unit**

emergency safety eye wash unit, that is permanently connected to a continuous water supply

NOTE According to DIN EN 15154-2.

3.6**combination shower**

emergency safety shower, where an emergency safety eye wash unit is suitably integrated into the plumbed-in safety body shower

4 Performance**4.1 Classification**

Body showers for production and logistic sites shall comply with one of the 3 classes given in Table 1.

Table 1 — Classification and volume flow rate

Class	Volume flow rate according to 4.2 L/min	Water distribution according to 4.3 ¹⁾
I	30 to 60	r 200: (50 ± 10) % r 400: > 95 %
II	> 60 to 100	r 200: (50 ± 10) % r 400: > 95 %
III	> 100	r 200: (50 ± 10) % r 400: > 70 %
¹⁾ For tank showers the water distribution of Class III applies irrespective of the volume flow rate (see also 4.3.3).		

4.2 Flow rate of water**4.2.1 Plumbed-in body showers**

The water supplied by plumbed-in body showers shall be of a constant flow rate discharged over-head in accordance with one of the 3 classes given in Table 1 at a flow pressure to be specified by the manufacturer. The plumbed-in body shower shall be capable of delivering this supply for a minimum of 15 minutes.

NOTE Attention is drawn to possible national regulations concerning the volume flow rate.

At the type test (see 4.3.1), the flow pressure shall be measured with fully opened valve at the point where the shower is connected to the water supply. The measured value shall be indicated in the manufacturer's information.

If plumbed-in body showers have two or more shower heads, the total water volume flow rate shall be at least 100 L/min; a minimum of (30 ± 5) L/min thereof shall discharge over the head of the user.

4.2.2 Tank showers

The water that is discharged by the tank shower has to be an over-head water volume flow rate out of the three classes according to Table 1.

Flow pressure, max. deviation of water volume flow rate and the duration of water flow shall be specified by the manufacturer and shall be declared in the manufacturer's information (see Clause 8).

4.2.3 Combination showers

For combination showers the respective specified water volume flow rate shall be kept at simultaneous actuation of both the body shower and the eye wash unit.

The emergency safety eye wash unit and its water flow rate shall comply to DIN EN 15154-2.

4.3 Water distribution

4.3.1 Type test

The water distribution of emergency body showers for production and logistic sites shall be measured by the following type test procedure.

4.3.2 Body showers of classes I and II

At a distance 700 mm below the shower head, (50 ± 10) % of the volume of water delivered shall fall in a circle with a radius r of 200 mm (see Figure 1); the water level in the individual compartments in this circle shall not deviate by more than 30 % from the mean value.

At this measuring level, the area reached by a minimum of 95 % of the water shall be limited to a circle with a radius r of 400 mm.

The velocity of the water spray shall be low enough to be non-injurious to the user.

NOTE All details of this type test procedure are in accordance with the test procedure for laboratory showers given in DIN EN 15154-1.

Dimensions in millimetres

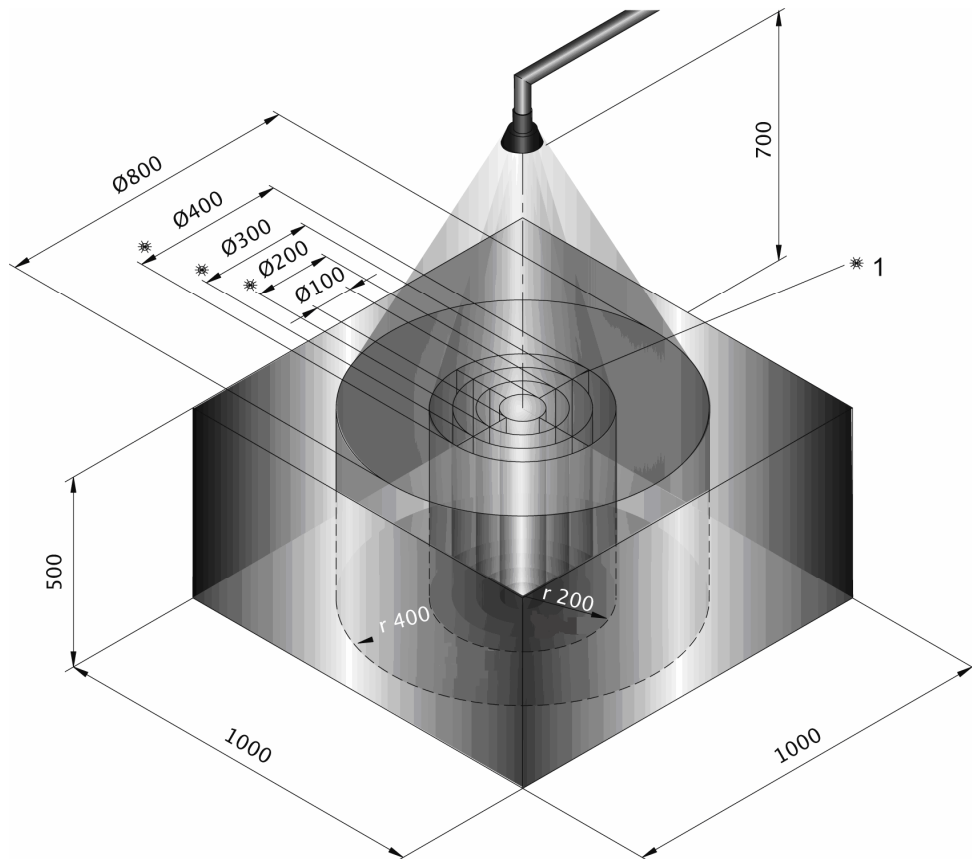
**Key**

* 1 Cylinder with 4 compartments

Figure 1 — Type testing of water distribution

4.3.3 Body showers of Class III and tank showers

At a distance 700 mm below the shower head, (50 ± 10) % of the volume of water delivered shall fall in a circle with a radius r of 200 mm (see Figure 1).

At this measuring level, the area reached by a minimum of 70 % of the water shall be limited to a circle with a radius r of 400 mm.

For body showers with more than one shower head, the water distribution of the over-head spray nozzle has to be the same as given above. The additional nozzles shall be concentrated on the centre axis of the user and their water volume flow rate shall not dominate the volume flow rate of the over-head nozzle.

The velocity of the water spray shall be low enough to be non-injurious to the user.

4.4 Water quality

Potable water or water of a similar quality complying with European or national standards is required for body showers.

Materials used in the construction of the shower shall not affect the water quality or contaminate the water supply.

4.5 Water availability

The required volume flow rate has to be reached 3 seconds at the latest after opening the shut-off valve, also in outdoor facilities.

4.6 Water temperature

According to DIN EN 15154-1.

5 Constructional installation requirements

5.1 Installation height

The shower head shall be designed to be installed so that its lower edge is (2200 ± 100) mm above the level on which the user stands.

On combination showers the integrated eye wash unit shall conform to the installation height according to DIN EN 15154-2.

5.2 Free space

The free space between the centre line of the shower head and the nearest obstruction (wall, vertical supply tube or similar) shall be a circle with a minimum radius r of 400 mm.

Only the valve control element and/or the eyewash station and/or the hand held shower on a combination shower shall project into this space by a maximum of 200 mm. Other parts or components shall not project into this space.

6 Valve

For manual operation, the valve shall be opened in a single operation by turning or moving a valve actuator to max. 90° or max. 200 mm stroke. The maximum force for the operation shall be 100 N or the maximum torque 7 Nm. By using this force/torque, the valve shall be fully open within 1 s.

A valve which is activated through a certain weight, e. g. by entering a platform, shall be completely open at a load of maximal 40 kg in the center of the platform (actuation).

Also for automatic operation or actuation through platform, the shut-off valve shall be fully open within 1 s.

The valve shall not close automatically once it has been opened, except for actuation platforms. The direction of operating the valve actuator shall be clearly visible and unmistakable.

The valve actuator shall be large enough to be easily located and operated by the user even when wearing protective gloves with a maximum size in accordance with EN 420. The valve actuator shall be positioned between floor level and max. 1750 mm above that level. Actuation platforms shall have a minimum size of 500 mm x 500 mm and must be placed axially to the height of fall of the shower head.

7 Shower head

It shall only be possible to make adjustments with a tool to the direction of spray or the water distribution of a shower head.

The shower head shall be self-draining between the valve and the outlet. The shower head shall be removable for maintenance but only by use of a tool.

8 Mechanical stability of tank showers

Tank showers shall be built according to structural calculations given in DIN 1055-100 to ensure the constructional stability. Where appropriate, wind loads according to DIN 1055-4 and snow loads according to DIN 1055-5 shall be considered.

9 Manufacturer's information

The manufacturer shall specify to which class according to this standard (see 4.1) the safety shower belongs. For safety showers with more than one shower head it shall be specified also the total volume flow rate in addition to the Class III.

The manufacturer shall supply with the emergency body shower information on installation, operation and maintenance as well as the method and frequency of routine testing.

For tank showers the manufacturer shall give full particulars for a suitable protection against microbial contamination and recommendations for the rate of water exchange.

10 Marking

The shower shall be clearly and permanently marked showing the Class (see 4.1), the requirements for minimum and maximum flow pressure and the maximum static pressure. Marking shall be performed by the manufacturer and shall show the name of the manufacturer and the model or article number.

In addition, a safety sign in accordance with ISO 3864-1 displayable near the shower shall be supplied with each emergency safety body shower.

On tank showers, the filling volume, the Class according to 4.1, the initial flow rate and the duration, how long the classified flow rate stands by shall be marked.